

Artificial Intelligence

Apergy™

*Rohit Robinson
Aug 2019*

FOLLOWING

ALL PROFILES ACCOUNTS

ARCHITECTURE



ROBOTICS



BUSINESS
By The News Desk



TECHNOLOGY
By The News Desk



TECHNOLOGICAL CHANGE

Andrew Yang: Americans' Problems Will Remain



NATURE



Spam Digest <spam_digest@apergy.com> ● Robinson, Rohit
End User Digest: 3 New Messages

Apergy End User Digest: 3 New Messages
For Rohit Robinson rohit.robinson@apergy.com

The messages in your personal Digest represent emails that have been filtered and sorted into different categories, giving you an opportunity to take action on them. Click the link in the Subject column to view the message.

[Request New End User Digest](#) [Request Safe/Blocked Senders List](#) [Manage My Digest](#)

The emails listed in this section represent low priority email such as newsletters, invitations, and announcements placed in your personal quarantine. If you want to receive email from the sender, click Allow Sender - future emails from the sender will be delivered to your inbox. Otherwise, click Block Sender to stop receiving email from the sender.

Low Priority Mail - Quarantined			
Score	From	Subject	Action
100	emily.nancarrow@franklincovey.com	Join Us: FranklinCovey Webinar Series	Release Allow Sender Block Sender
100	info@connections.te.com	Preventing Machine Downtime: Vibration Sensors in Condition Monitoring Applications	Release Allow Sender Block Sender
100	Sarah.Feldman@statista.com	Statista's The Week Ahead - The Hajj Is Among the Biggest Gatherings in the World	Release Allow Sender Block Sender

- 170 billion images from 87 countries
- Machine Learning is used to map out building outlines. ML mapped more buildings in 1 year than in the prior 10

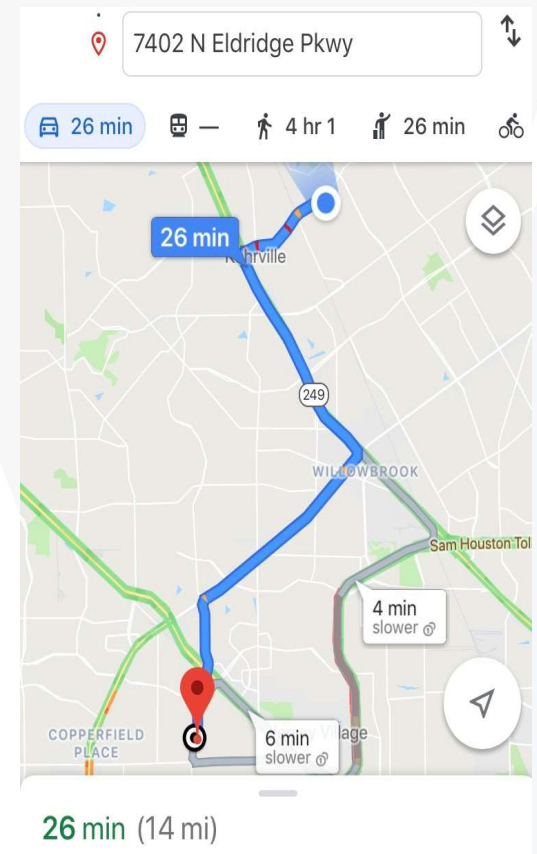

Dartmouth 1956

- J. McCarthy invited researchers to: *“proceed on the basis of the conjecture that every aspect of learning or any other feature of intelligence can in principle be so precisely described that a machine can be made to simulate it. An attempt will be made to find how to make machines use language, form abstractions and concepts, solve kinds of problems now reserved for humans, and improve themselves.”*
- *“We propose that a 2 month, 10 man study of **artificial intelligence** be carried out”*



Modern day descriptors

- Simulate human intelligence
- Be able to perform cognitive functions such as thinking, learning, language processing, visual recognition, decision-making
- Be able to problem solve, anticipate

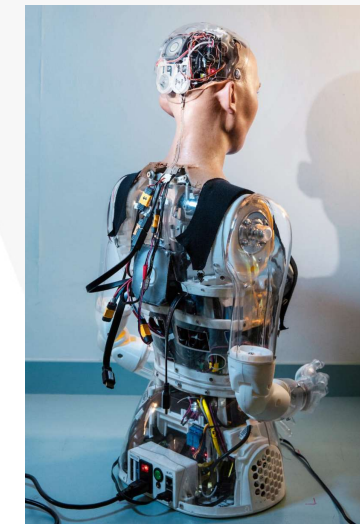
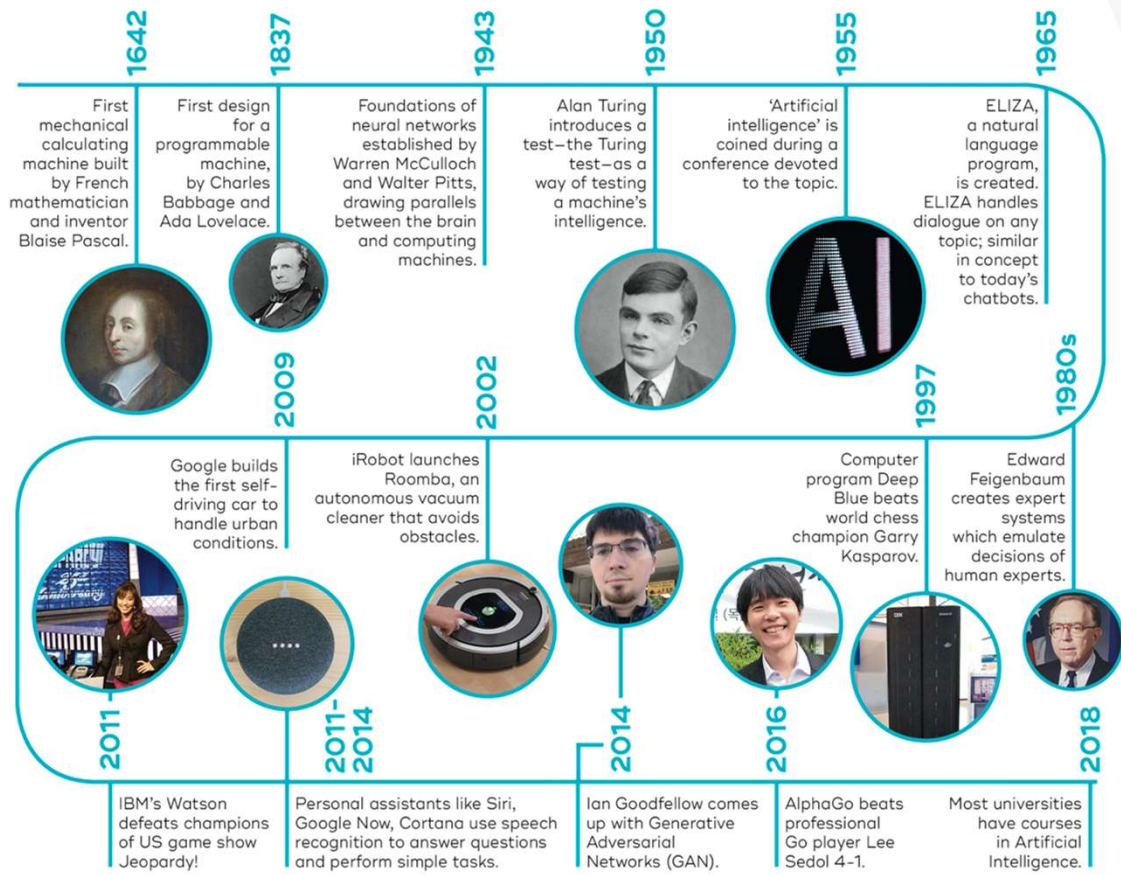

The business value of AI

“In approximately 60% of occupations, at least 30% of constituent activities are technically automatable by adapting currently proven AI technologies” – McKinsey Global Institute

AI can completely/partially take on these activities

- Sift through large volumes of data
- Look for correlations in data
- Ingest and analyze high velocity data
- Generate reasonable insights, infer path forward
- Optimize towards a specific objective, while remaining within constraints

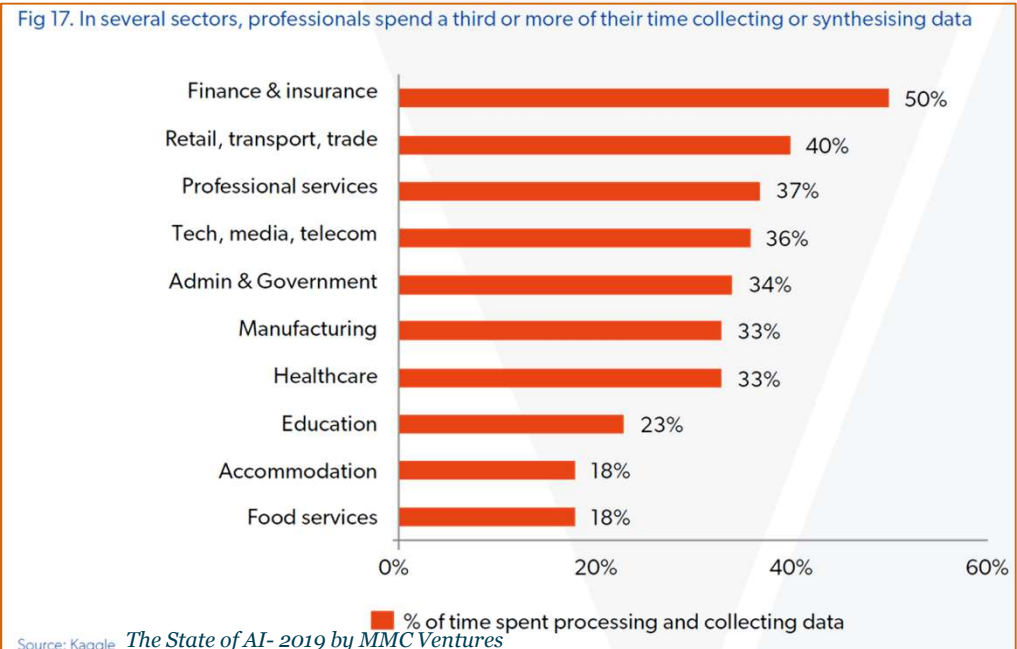

A sampling of AI Use Cases in Oil and Gas

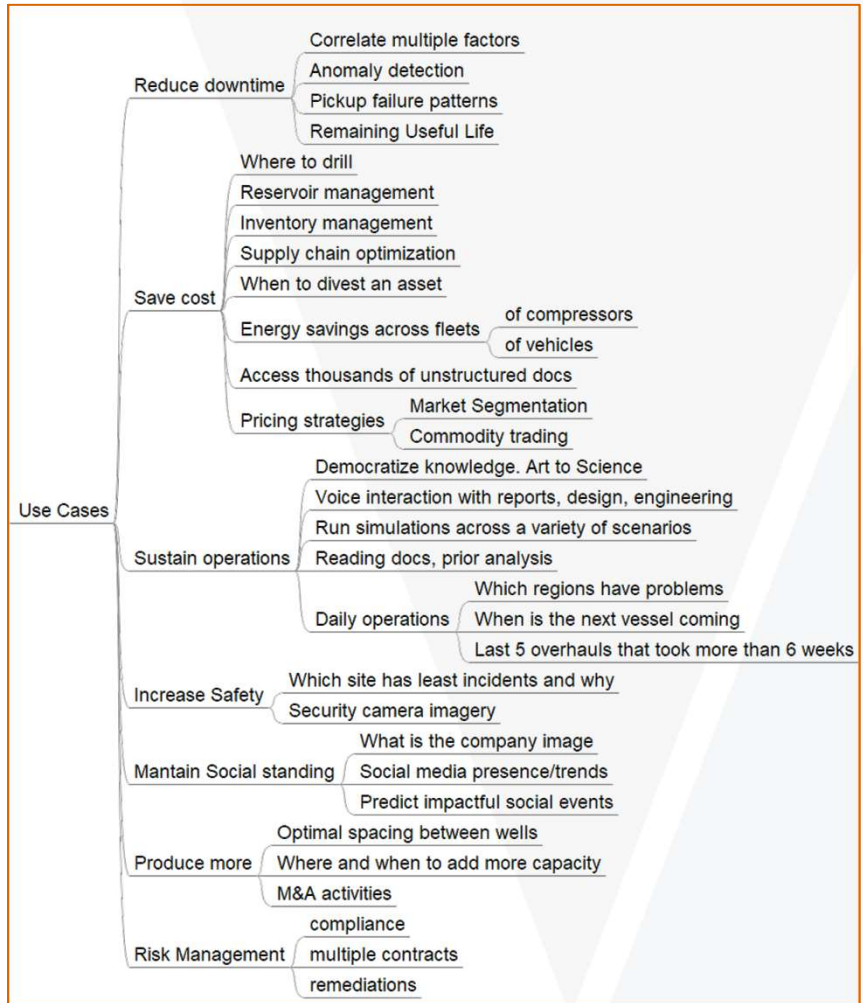
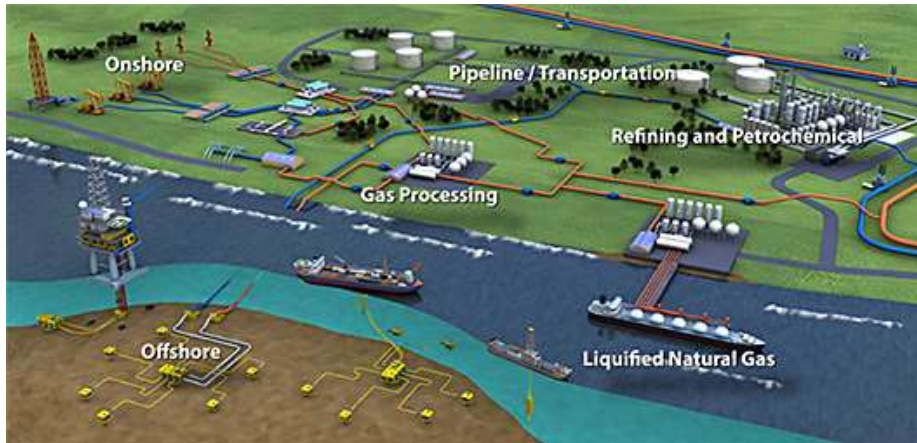

Types of Machine Learning

- Used to draw inferences from datasets consisting of input data without labeled responses
- Amazon uses this method to group buyers into different categories and recommend products

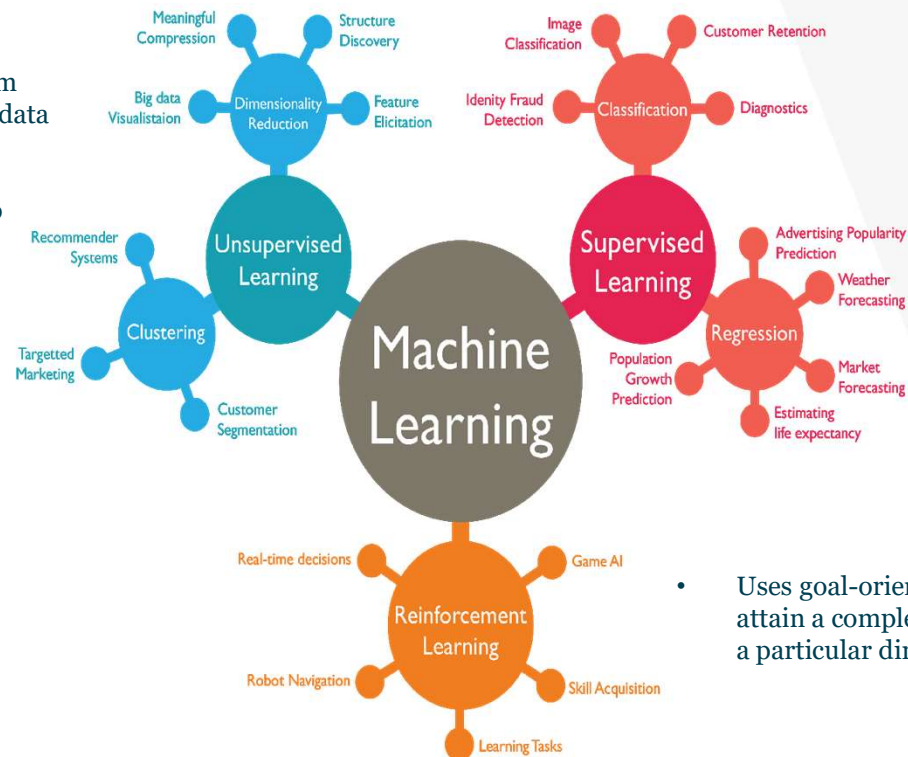

- Uses labeled data to train models and predict an outcome(s) based on the model
- Bank fraud data are used to train fraud detection models

- Uses goal-oriented algorithms, which learn how to attain a complex objective (goal) or maximize along a particular dimension over many steps

How does AI work



A Neural Network is a **function** that can learn

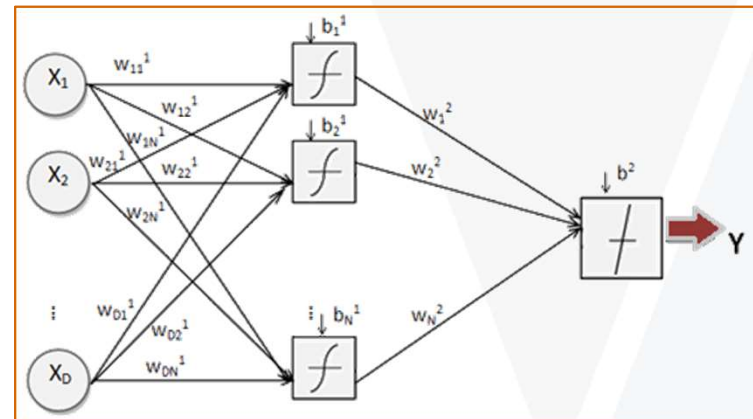
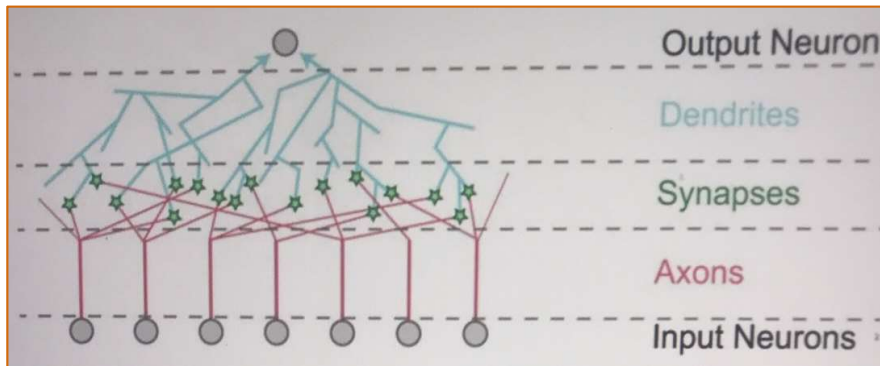
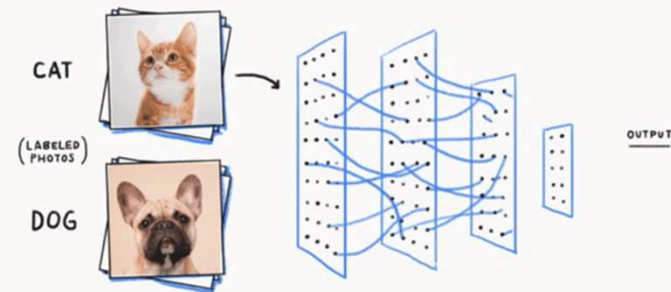

One of our use cases

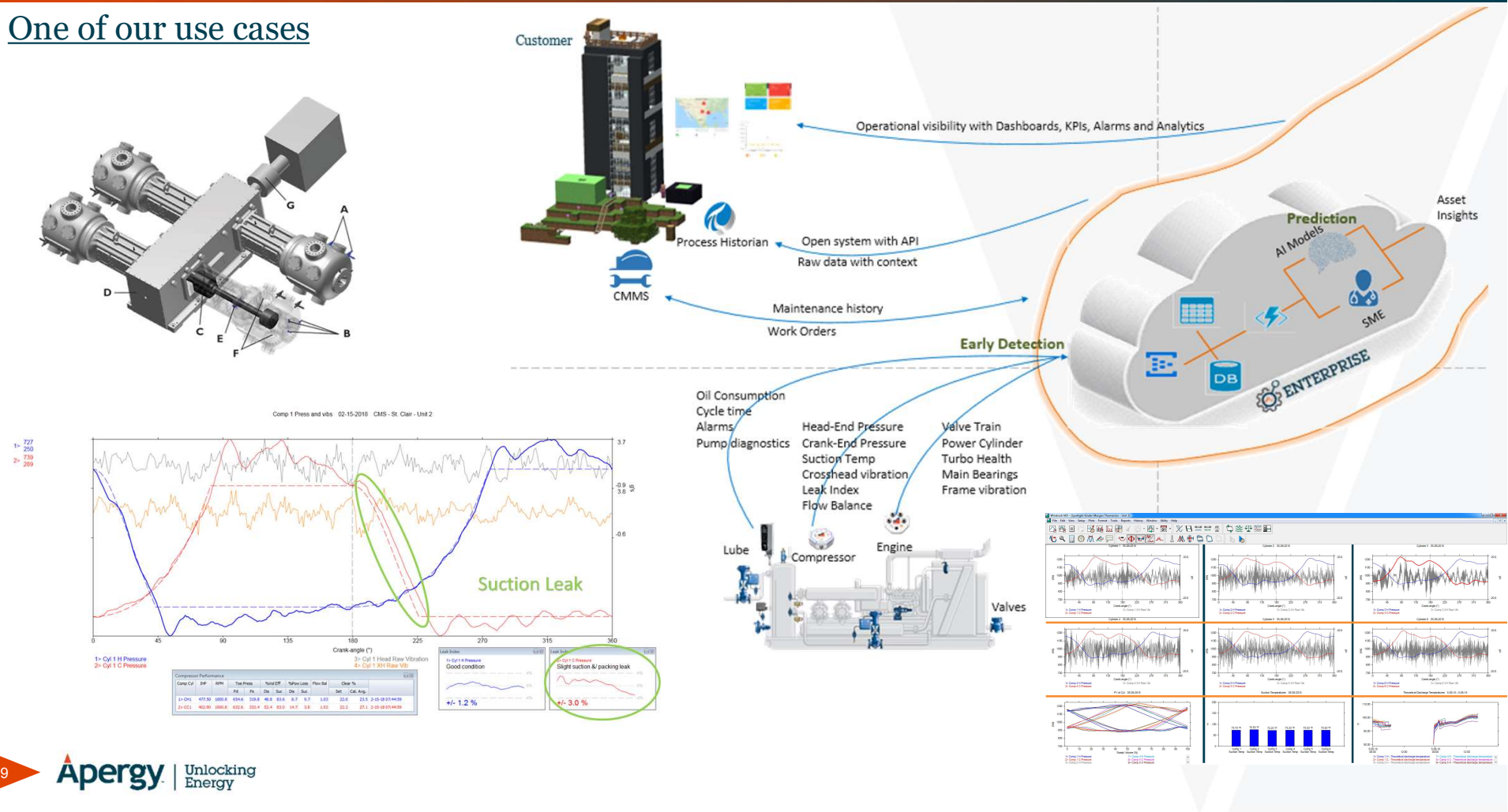

Why did we pick AI

- Limited resources to monitor hundreds of assets in real time
- Differences in opinions in deciding if an asset has a certain issue
- Unable to predict an issue earlier due to undetected trend in the data
- Unable to detect multiple issues at the same time

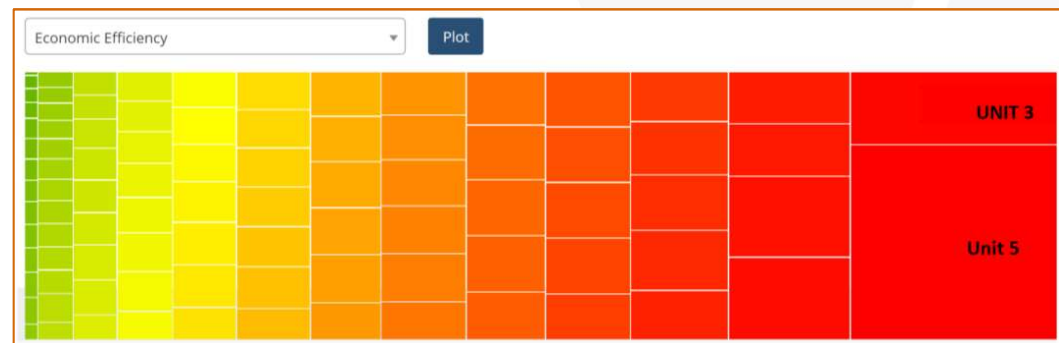
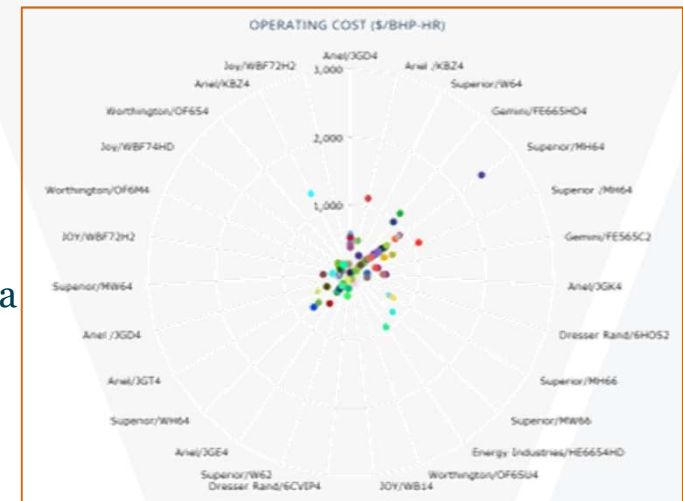

Unleashing AI on Compressor Monitoring

Data selection

- 10 Compressors with a variety of features and values to get the best possible sampling
- A total of 14 different features were selected to build the valve leak model
- Data was labeled as 4 different levels
 - Level 0: Normal
 - Level 1: Mild Leak
 - Level 2: Medium Leak
 - Level 3: Severe Leak

- Feature engineering is the process of using domain knowledge of the data to create features to explain a certain circumstances. E.g. adding, subtracting, multiplying, or dividing two features or more into a single feature

Suction volume ranges from 20 percent to 90 percent

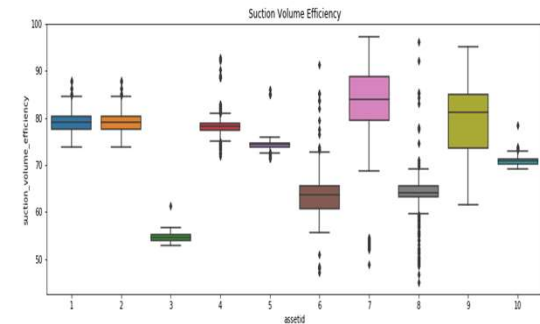

Discharge temperature ranges from 60 F to 300 F

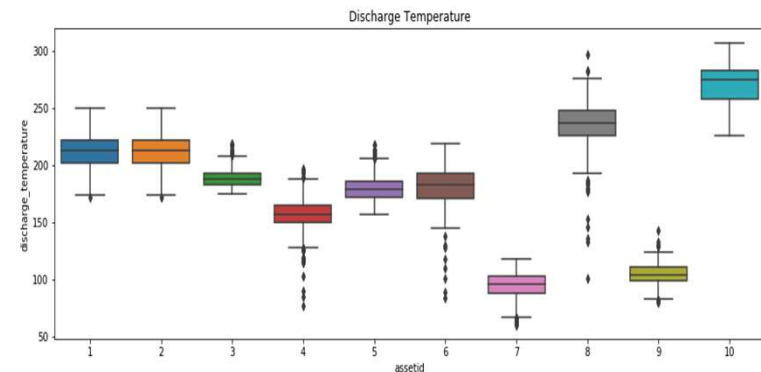

Unleashing AI on Compressor Monitoring

Results

- A supervised learning model for leak detection and a Neural network model for anomaly detection

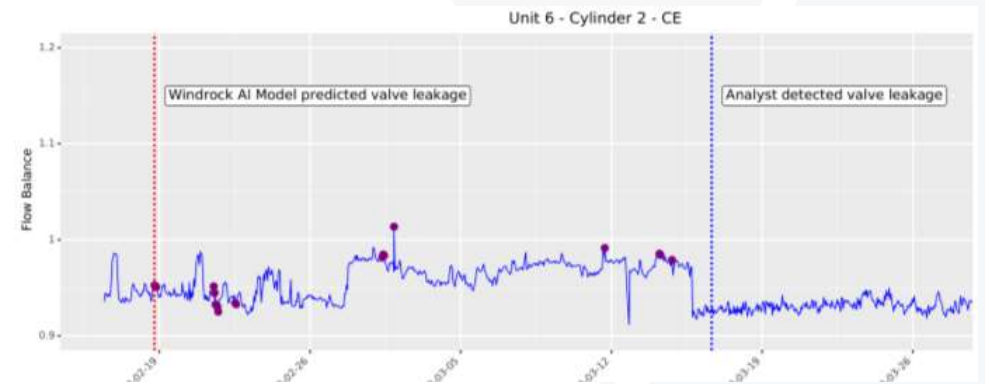
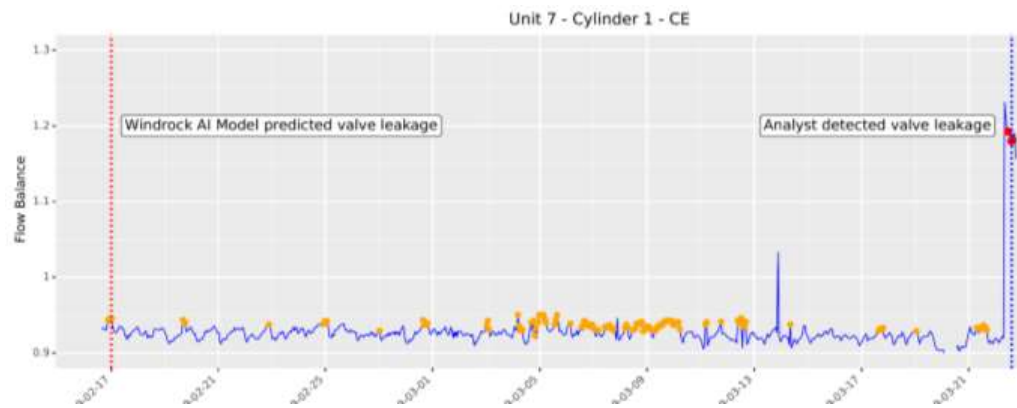

Points to ponder

- Transparency & the Engineer's mindset
- A Precision machine
- Data Availability & Veracity
- Integrity and values
- Bias
- Accountability
- Imperfect image recognition
- Cyber attacks on AI models

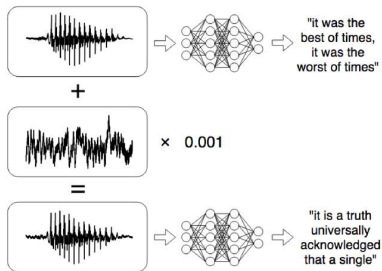

The New York Times
 Alexa and Siri Can Hear This Hidden Command. You Can't.

[Carlini et al. 2016][Carlini Wagner 2018]:
 Voice commands that are unintelligible to humans



[Athalye Engstrom Ilyas Kwok 2017]

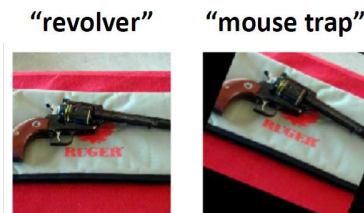

[Engstrom Tran Tsipras Schmidt M 2018]



[Simen Thys, Wiebe Van Ranst, Toon Goedeme]

Considerations for enterprise deployment

- Executive sponsorship
- Enterprise awareness
- Potential impact on workforce
- Factor in scalability
- IP ownership
- Contractual SLAs
- Time to value
- Risk aversion
- The Silver bullet

Thank you!



Apergy.

Rohit Robinson
VP, Product Mgmt. & Strategic Marketing
Digital Automation

O: 281.403.5715

M: 832.465.8432

E: Rohit.Robinson@apergy.com

Apergy
2445 Technology Forest Blvd.
Building 4, 12th Floor
The Woodlands, TX 77381

apergy.com